

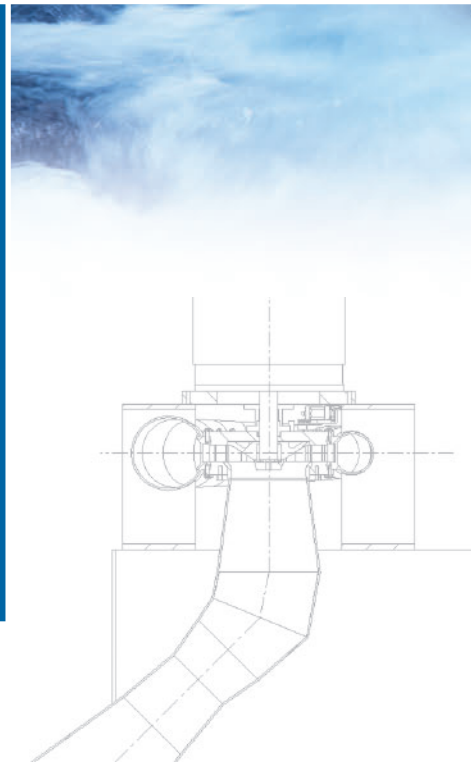

Hydroelectric Systems for Utilities  
and Independent Power Producers



Located in British Columbia, Canada, this Canyon Hydro system uses twin Pelton turbines producing 3,000 kW each, from 316.8 meters (1,040 feet) net head. With technician Spencer New.



## Efficient, Reliable Hydro Systems to 25 MW

Hydroelectric systems from Canyon Hydro deliver exceptionally high efficiency and reliability. Built for continuous, uninterrupted power generation, they deliver a high return on your investment year after year.

Each Canyon Hydro system is custom-designed for a specific site, resulting in greater water-to-wire power transfer than off-the-shelf alternatives. Efficient design combined with premium quality components, exacting workmanship, and responsive customer support are why the Canyon brand is among the most respected in the industry.

In business for more than 30 years, the Canyon Hydro team of experts is dedicated to the success of your project.

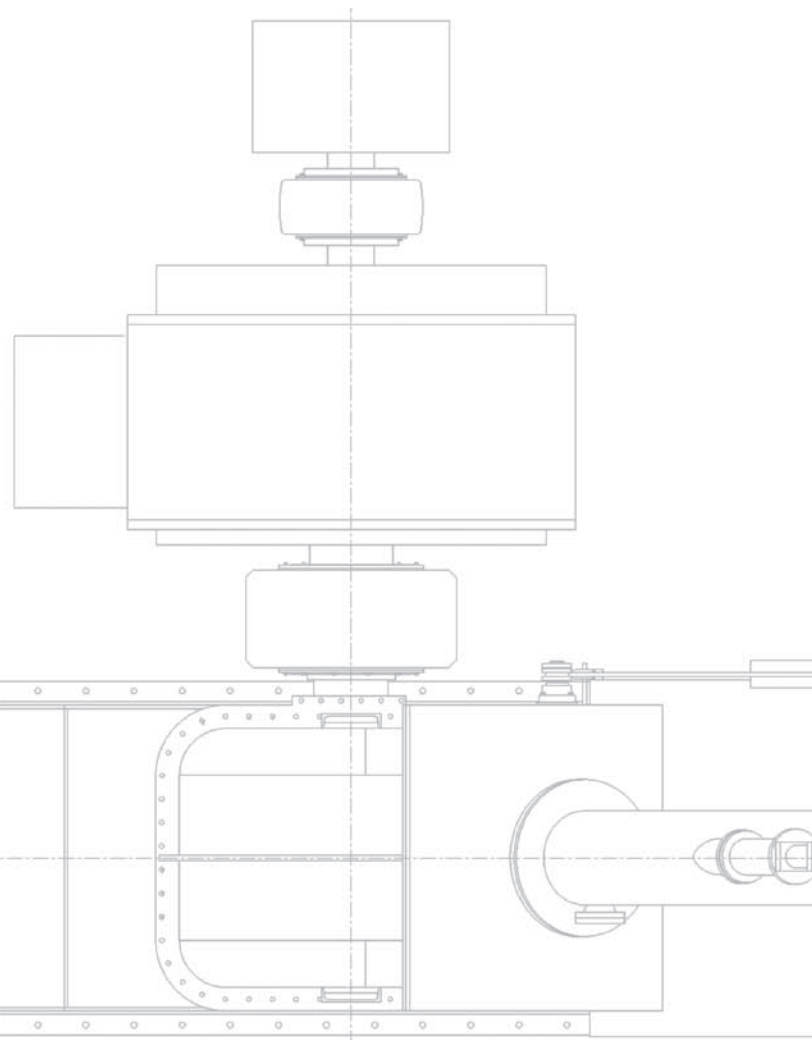

## Turbines Designed for Your Project

The heart of a hydro system is the turbine, where power is extracted from your water. Efficiency is critical here, because every small gain – or loss – directly affects your profit margin.

At Canyon Hydro, our engineers are committed to maximum efficiency, which is why we don't offer "standard" systems that have been averaged to

service a wide variety of installations. Each Canyon turbine is individually designed to match the specific hydraulic characteristics of the site. Your turbine will be carefully engineered to match your head, flow, penstock, and other site considerations. The difference in power output is measurable, and the cost may be less than you expect.



Every Canyon Hydro turbine undergoes extensive inspections and non-destructive testing. Here, Canyon Chief Engineer Brett Bauer inspects a Pelton runner destined for PG&E's 1,880 kW Phoenix project in California, with a net head of 308.75 meters (1013 feet).

## Superior Design and Workmanship

Throughout the design and manufacture of your turbine, Canyon Hydro maintains meticulous attention to quality.

The process begins with computer modeling to determine the optimum turbine characteristics for your site. Each turbine is then designed, with critical elements validated by Finite Element Analysis (FEA) and Computational Fluid Dynamics (CFD) methods. Manufacturing drawings are produced in-house and reviewed by engineers and production supervisors. Final design drawings are provided to you in hardcopy and CAD format to facilitate your powerhouse design.

All of this adds up to highly efficient, extremely durable hydraulic turbines capable of delivering many years of reliable power generation.

The La Esperanza powerhouse during the construction phase. Canyon Hydro president Dan New, center.

## Water-to-Wire Packages

Using the industry's finest turbines as a foundation, Canyon Hydro water-to-wire packages provide all the equipment you need for your powerhouse.

As with our turbines, efficiency and durability are the highest priorities for our powerhouse packages. From shaft materials and bearings to generators and switchgear, every component is selected to ensure maximum possible power output and minimum chance of failure.

Turbines are matched with generators early in the design stage to ensure optimum integration and efficiency. Generators are carefully selected to meet the demands of hydroelectric installation, and sourced only from reputable manufacturers.

Controls and switchgear are designed to meet specific inertia requirements and project control schemes. For stand-alone projects, complete electro-hydraulic governing systems are employed to provide utility-quality power for remote sites.

A Canyon Hydro water-to-wire package is your assurance that every effort has been taken to ensure efficient, long-term performance.

## Upgrade Your Existing Hydro System

Canyon Hydro applies this same attention to detail for customers needing replacement components for existing systems. Within the constraints of existing powerhouses, turbines, nozzles, and generators, Canyon Hydro engineers will design the new components to deliver the highest possible efficiency.

Three-dimensional models are created from CAD drawings, laying the groundwork for patterns and castings. Runner castings are tightly controlled, following rigid specifications for alloys, chills, core assemblies, and other requirements. Before the runner is released for final machining and balancing, it undergoes non-destructive testing and heat treating.

Our goal at Canyon Hydro is to build replacement components that deliver more power and last longer than your originals.

The completed La Esperanza powerhouse, located in Honduras. This dual-turbine project produces 12,000 kW from 370 meters (1,214 feet) net head.



## A Response Team to Back You Up

With proper maintenance, a Canyon turbine will provide dependable service for decades. If a problem does arise, you have the best support team in the business to back you up.

System availability is Canyon's highest priority. If your hydro system should fail – whether or not Canyon Hydro built it – recovery takes priority over all other Canyon projects. Replacement parts are air-shipped and, if necessary, senior engineers will fly on-site to help resolve the problem.

Rapid response is possible because you rarely have to wait for Canyon to order parts from third-party suppliers. With the exception of foundry castings, Canyon Hydro manufactures all of its own turbine components.



Canyon Hydro offers extensive services for component rebuilding or replacement. This Pelton runner, originally built in 1923, was provided by Canyon Hydro for a 6,100 kW project in Montana. Also note the remanufactured variable needle nozzle provided by Canyon.

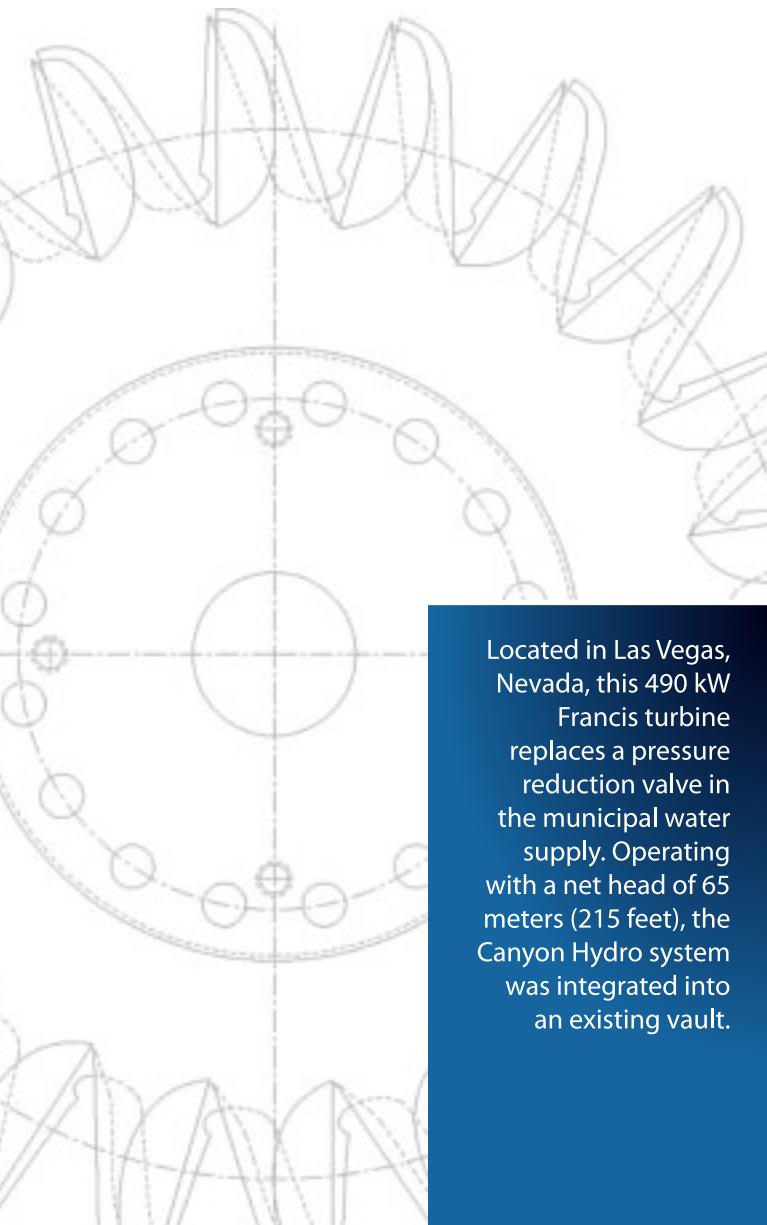

Located in Las Vegas, Nevada, this 490 kW Francis turbine replaces a pressure reduction valve in the municipal water supply. Operating with a net head of 65 meters (215 feet), the Canyon Hydro system was integrated into an existing vault.



## Commitment to Total Project Success

When you specify a Canyon Hydro system, you also get a highly experienced partner committed to the success of your project.

Canyon has been building hydropower systems for more than 30 years, and we've been involved with hundreds of projects. We'll work closely with you, assisting with site planning and design, and suggest improvements or alternatives based on our experience. We can help identify ways to accelerate your project, improve efficiency, and ensure uninterrupted power production.

Canyon Hydro is not a large company, which gives us a unique advantage. By specializing only in small hydro systems, Canyon is able to provide custom-designed turbines and excellent delivery times at prices competitive with general-purpose systems.

Most of all, we love what we do. Canyon Hydro is a highly skilled team who, for four generations, has believed that quality craftsmanship and customer satisfaction are their highest priorities.

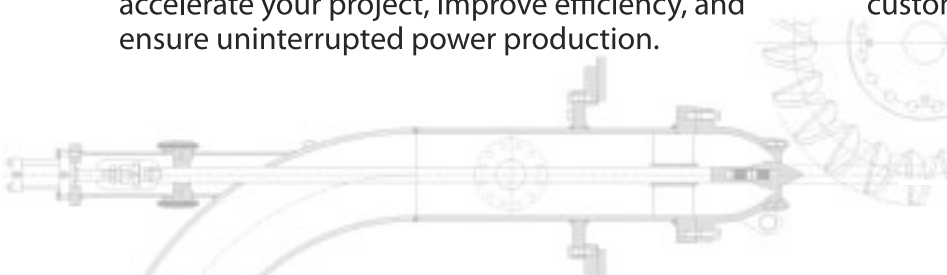

Canyon Hydro designed and delivered the complete water-to-wire equipment package for a Colorado Springs Utility powerhouse. This 540 kW system, located near the base of Pike's Peak, has a net head of 209 meters (686 feet).

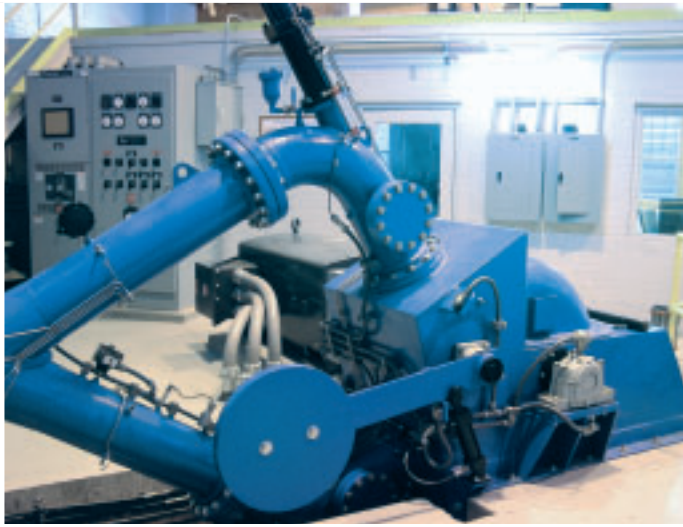

Located near Logan, Utah, this 300 kW Canyon Hydro system utilizes a Kaplan-type turbine operating under 9 meters (30 feet) net head, with a design flow of 4.05 cubic meters per second (143 cfs).

For more information about Canyon Hydro, or for a site evaluation and quotation, please contact us:

call: 1-360-592-5552  
fax: 1-360-592-2235

email: [turbines@canyonhydro.com](mailto:turbines@canyonhydro.com)  
web: [www.canyonhydro.com](http://www.canyonhydro.com)

© Canyon Industries - All rights reserved.  
Canyon Hydro is the waterpower division of Canyon Industries, Inc.



Canyon Hydro  
P. O. Box 36  
Deming, WA 98244 USA